

3 - SPEED SMARTAMTIC TRANSMISSION

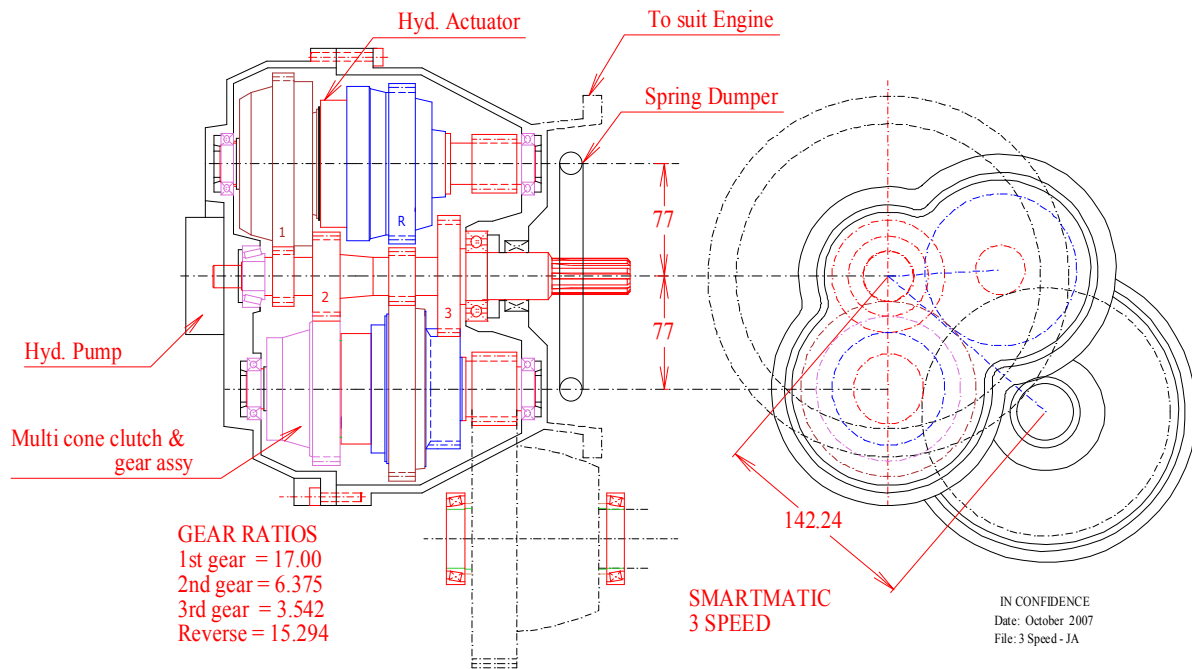

Transmission Specification:

1. 3 speed box. Suitable for small cars and motorcycles.
2. It can be used as 4 speed box for motorcycles (converting reverse into 4th gear).
3. First & reverse gear selectors are 1500 Nm torque capacity.
4. Hydraulic pressure: 10 - 60 bar (depends on engine torque)
5. Multi-cone gear selectors :
 - Composite friction paper.
 - Max operating temp 316° C.
 - Max operating surface pressure 172.4 N/cm².
 - Friction coef. Static=0.12; Dynamic=0.11.
 - Friction area: smallest clutch 145 cm², largest 320 cm².
 - Heat generation: 20 to 550 kJ/s in auto mode.
6. Cooling by convection, external fins on housing.
7. Launch clutch is not required. But it can be added.
8. Internal forces are contained within shafts.

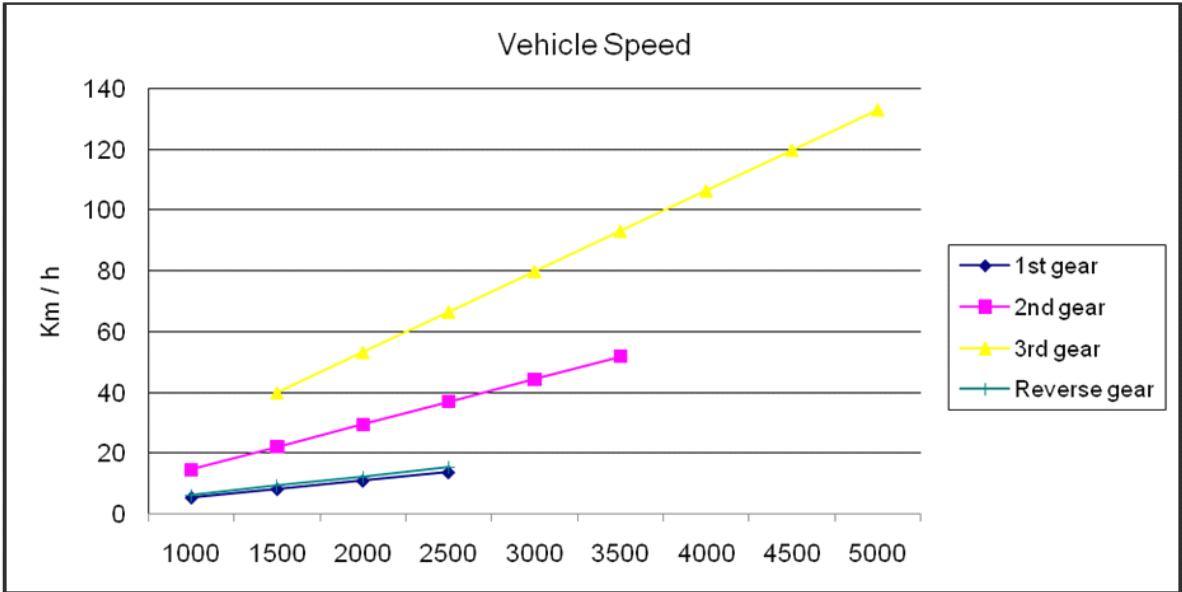

RPM